

IMPORTANT!! PLEASE READ ENTIRE INSTRUCTION SHEET BEFORE ASSEMBLY!!

Step 1: CAREFULLY remove glass and set aside until Step 7. Lay glass flat--do not stand on edge. Set parts on a flat, non-abrasive surface. Remove all protective materials. Identify all parts packed in carton against the parts list. If you are missing any parts, or are unsure how to proceed with assembly, call our Customer Service Center at 1-800-416-3511. **Do not attempt to assemble the table if any parts are missing or damaged.**

Step 2: Place the table rim (without glass) upside down on a flat, non-abrasive surface to avoid scratching the rim. Attach a leg to the rim using a (1/4"x20mm) bolt. Add a washer to bolt, then guide this into the pre-drilled hole already in place in the table rim. Hand tighten bolts. Repeat on the other three legs. **Important note: Hand tighten bolts only for this step. Do not over tighten. Some adjustments may be necessary to ensure table legs are aligned properly.**

Step 3: Attach a topside support to the rim using the (1/4"x20mm) bolt. Add a washer to each bolt, then guide into the pre-drilled hole in the table rim. Hand tighten bolts. Repeat on the other side. **Important note: Hand tighten bolts only for this step. Do not over tighten. Some adjustments may be necessary to ensure table legs are aligned properly.**

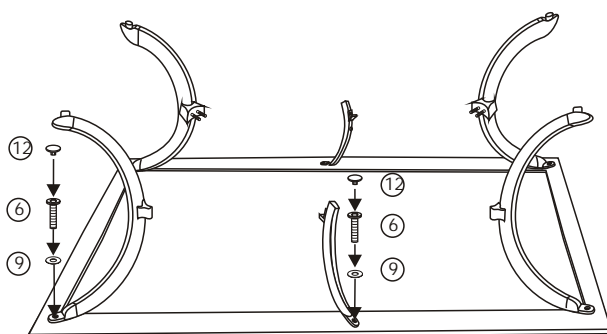

Step 4: Attach a leg to the leg connector bracket by carefully guiding the bolts already in place on the table legs (each leg has two bolts) through the holes in the leg connector bracket. Add a washer and a nut to the end of each bolt. **Hand tighten only.** Repeat on other three legs.

Step 5: Using a (1/4"x25mm) bolt, attach a topside support to the leg connector bracket. Add a washer to each bolt, and guide this through the inside of the leg connector bracket, and into the fixed nut already in place in the topside support. **Hand tighten only.** Repeat for other side.

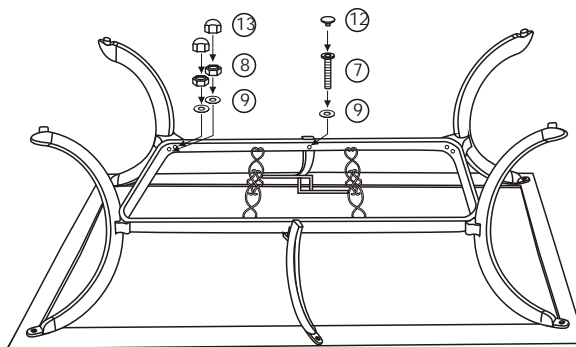

Step 6: At this time, make any minor adjustments in the alignment of the table legs or topside supports. Once you have legs and topside supports in the correct position, use the Hex Bolt Drive and Hex Wrench provided to tighten all nuts and bolts. Note: Each bolt must be tightened a few revolutions at a time. In order to apply even pressure, we recommend you alternate between nuts and bolts, working in a cross corner ("X") fashion. **DO NOT OVER TIGHTEN.** Cover all nuts and bolts with PVC covers.

Step 7: With the help of another person, turn the table in the upright position. Note the clear bumpers spaced evenly throughout the inside of the table rim. CAREFULLY place the glass inside the rim, resting on the clear bumpers. Your table is ready for use. If you have any questions, please call our customer service department (800) 416-3511.

	PARTS LIST	DESCRIPTION	QTY./PCS
1		GLASS TOP	1
2		TABLE RIM	1
3		LEG CONNECTOR BRACKET	1
4		TABLE LEG	4
5		TOPSIDE SUPPORT	2
6		1/4"x20MM BOLT	6
7		1/4"x25MM BOLT	2
8		NUT	8
9		WASHER	16
10		HEX WRENCH	1
11		HEX BOLT DRIVER	1
12		PVC BOLT COVER	8
13		PVC NUT COVER	8

MODEL # 553860-22-487